

Sistema Scorrevole a Chiusura Rallentata

Soft Closing Sliding Door System

Portata Max. 40Kg

Max. Capacity 40Kg

Istruzioni di montaggio

Assembling Instruction



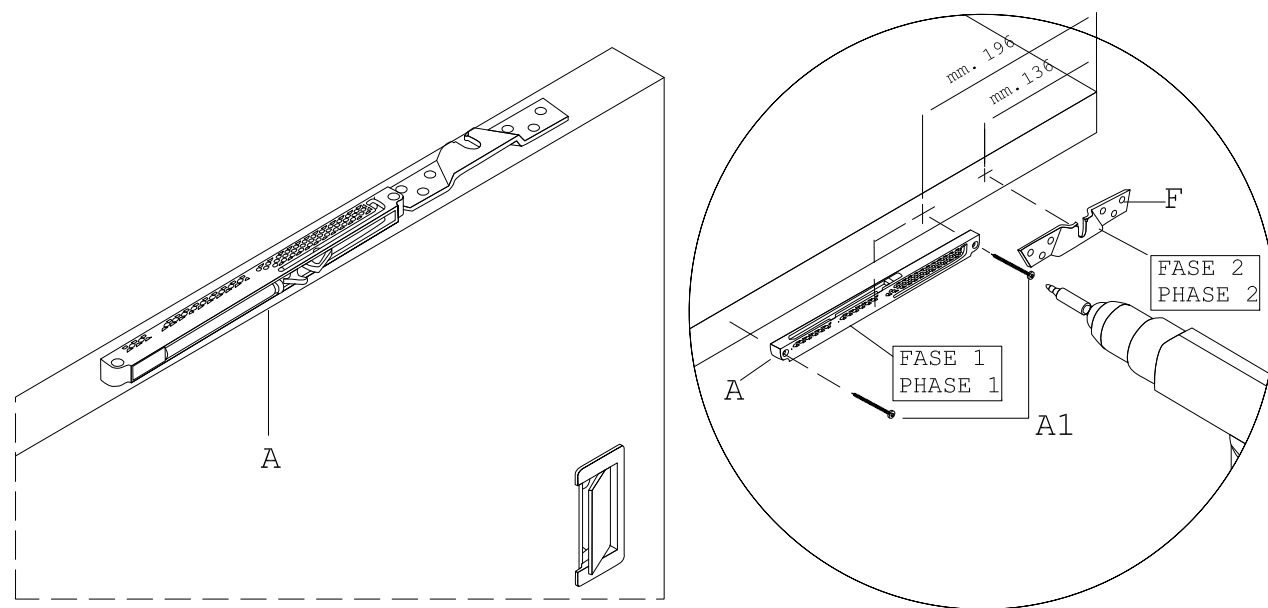

 *Fissare il sistema di chiusura "A" alla porta secondo le quote indicate. Utilizzare le viti in dotazione. Applicare prima il sistema di chiusura "A" (fase 1) e successivamente la staffa al carrello "F" (fase 2).

 * Fix the closing kit "A" to the door following the sizes indicated. Use screws contained in the kit. Fix first closing system "A" (phase 1) and then the bracket for roller (phase 2).

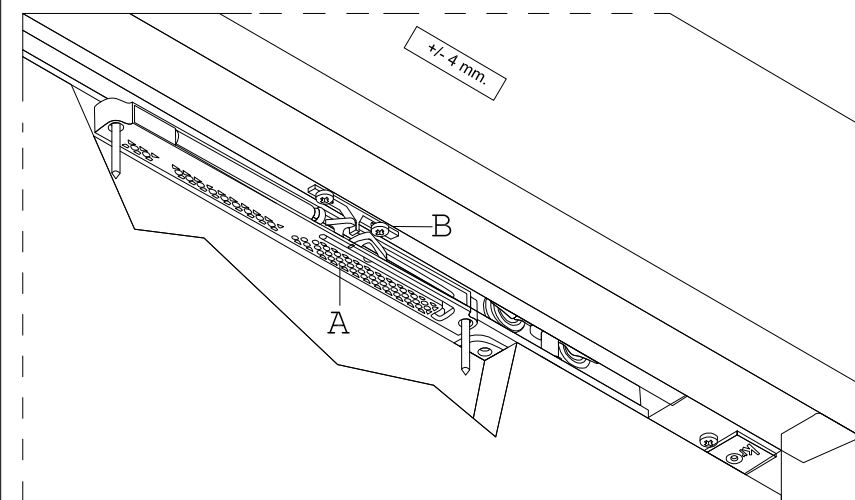

1



 *Installato il pannello, portarlo in battuta in chiusura e regolare, se necessario, la staffa "B" allentando le viti. Verifica finale: aprire la porta e scaricare il sistema di chiusura "A". Chiudere la porta verificando il corretto aggancio tra "A" e "B".

 * After having installed the door panel, bring it to the door stop and, if necessary, regulate bracket "B" by loosening the screws "B1". Final check: Open the door and discharge closing kit "A". Close the door and check the correct coupling between "A" and "B".

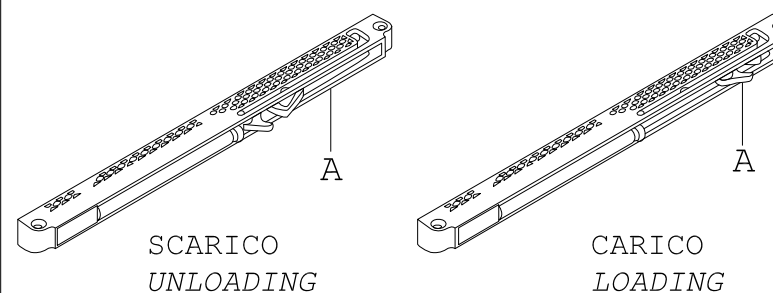

3

2

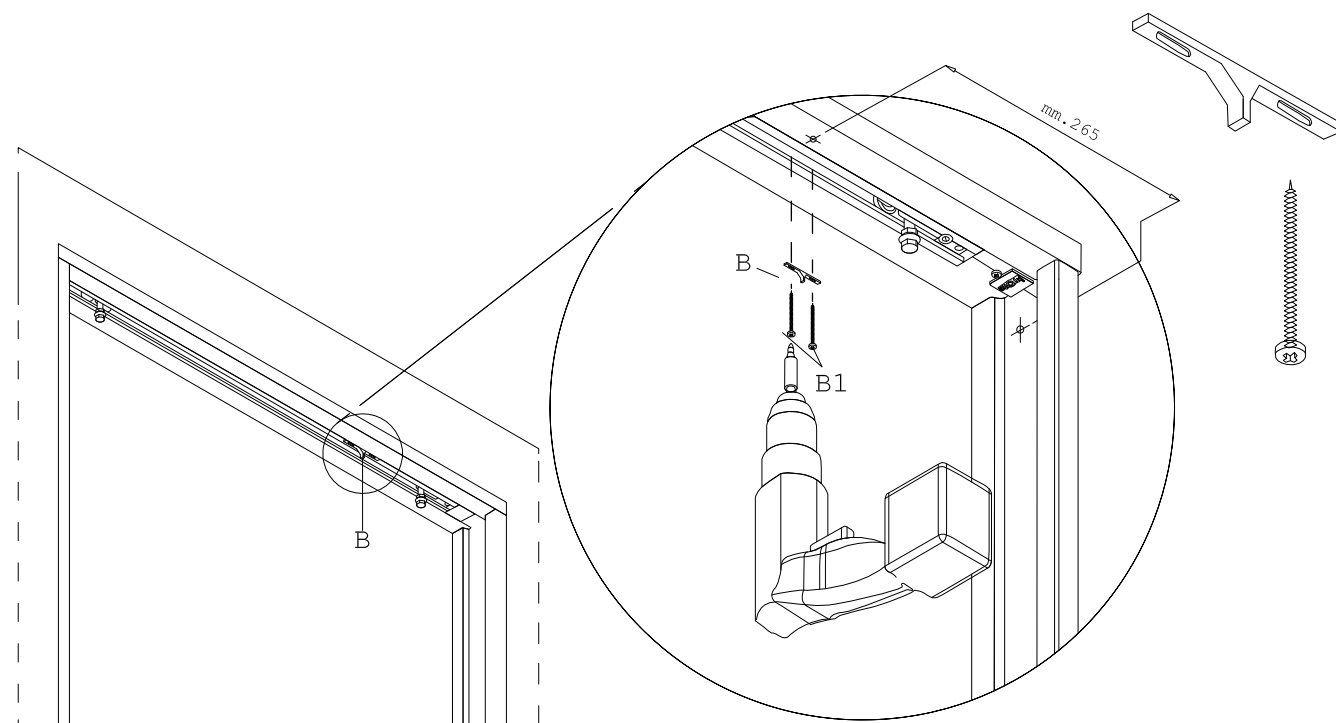

 *Fissare la staffa di chiusura "B" sul traverso. Utilizzare le viti in dotazione. Per il suo posizionamento fare riferimento alle quote indicate.

 * Fix closing bracket "B". Use screws contained in the kit. For the positioning kindly refer to the sizes indicated.

Contenuto del kit / Kit Contents:

N°1
Molla rallentatore /
Slow Spring

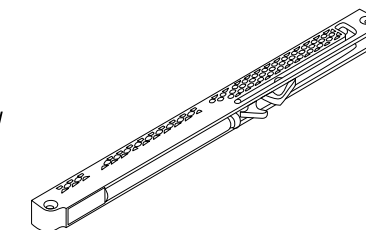

N°1
Staffetta d'aggancio /
Attachment Bracket

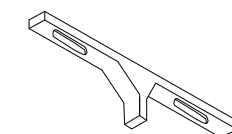

N°4
Viti di fissaggio /
Fixing Screws

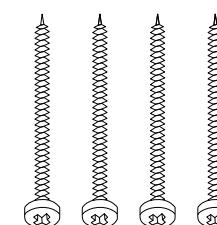

Sistema Scorrevole a Chiusura Rallentata

Soft Closing Sliding Door System

Portata Max. 80Kg

Max. Capacity 80Kg

Istruzioni di montaggio

Assembling Instruction



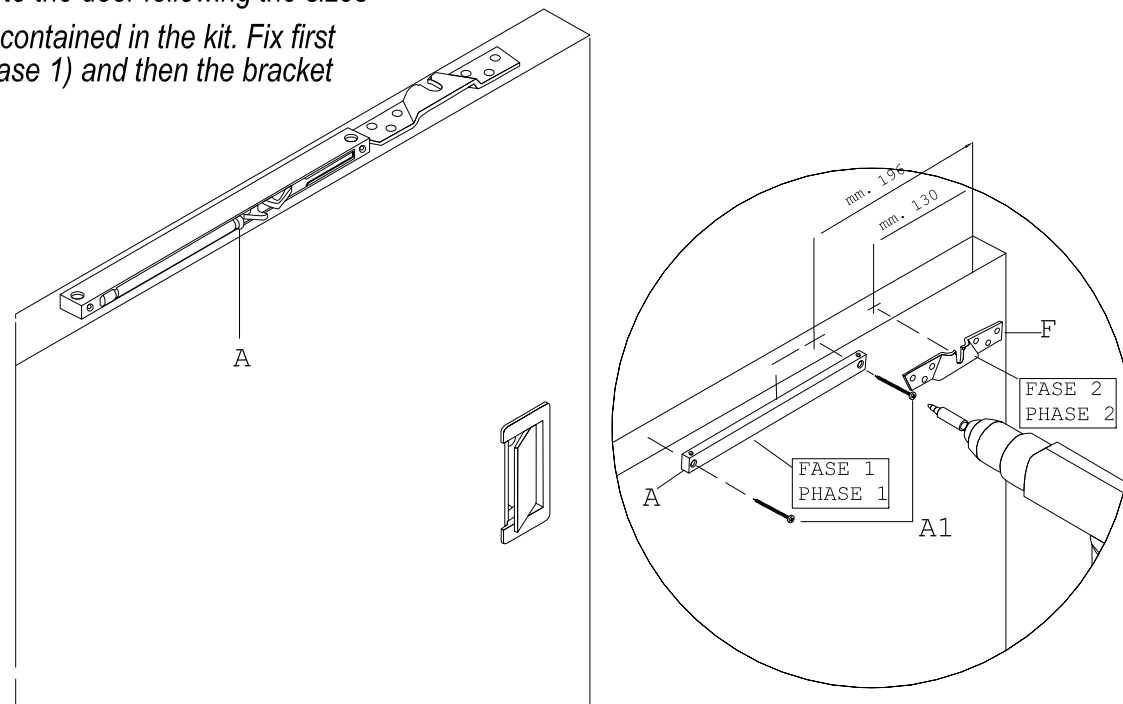

 *Fissare il sistema di chiusura "A" alla porta secondo le quote indicate. Utilizzare le viti in dotazione. Applicare prima il sistema di chiusura "A" (fase 1) e successivamente la staffa al carrello "F" (fase 2).

 * Fix the closing kit "A" to the door following the sizes indicated. Use screws contained in the kit. Fix first closing system "A" (phase 1) and then the bracket for roller (phase 2).

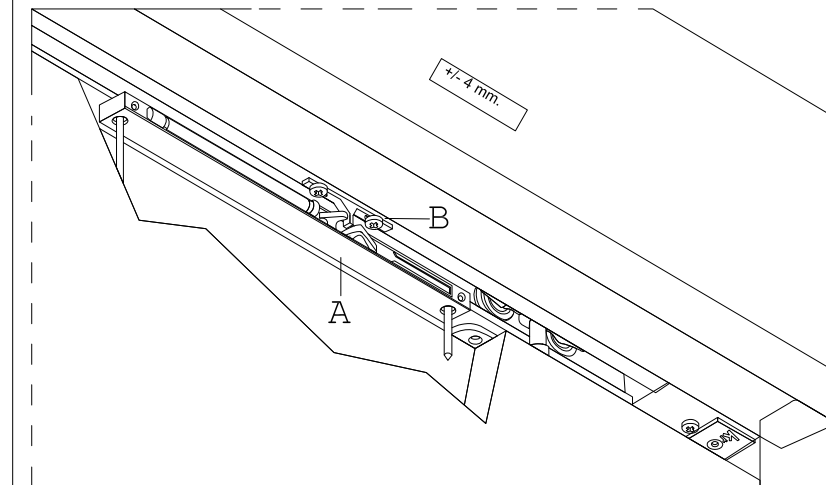

1



 *Installato il pannello, portarlo in battuta in chiusura e regolare, se necessario, la staffa "B" allentando le viti. Verifica finale: aprire la porta e scaricare il sistema di chiusura "A". Chiudere la porta verificando il corretto aggancio tra "A" e "B".

 * After having installed the door panel, bring it to the door stop and, if necessary, regulate bracket "B" by loosening the screws "B1". Final check: Open the door and discharge closing kit "A". Close the door and check the correct coupling between "A" and "B".

3

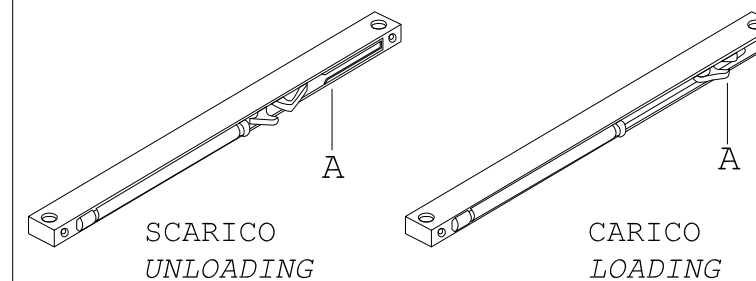

2

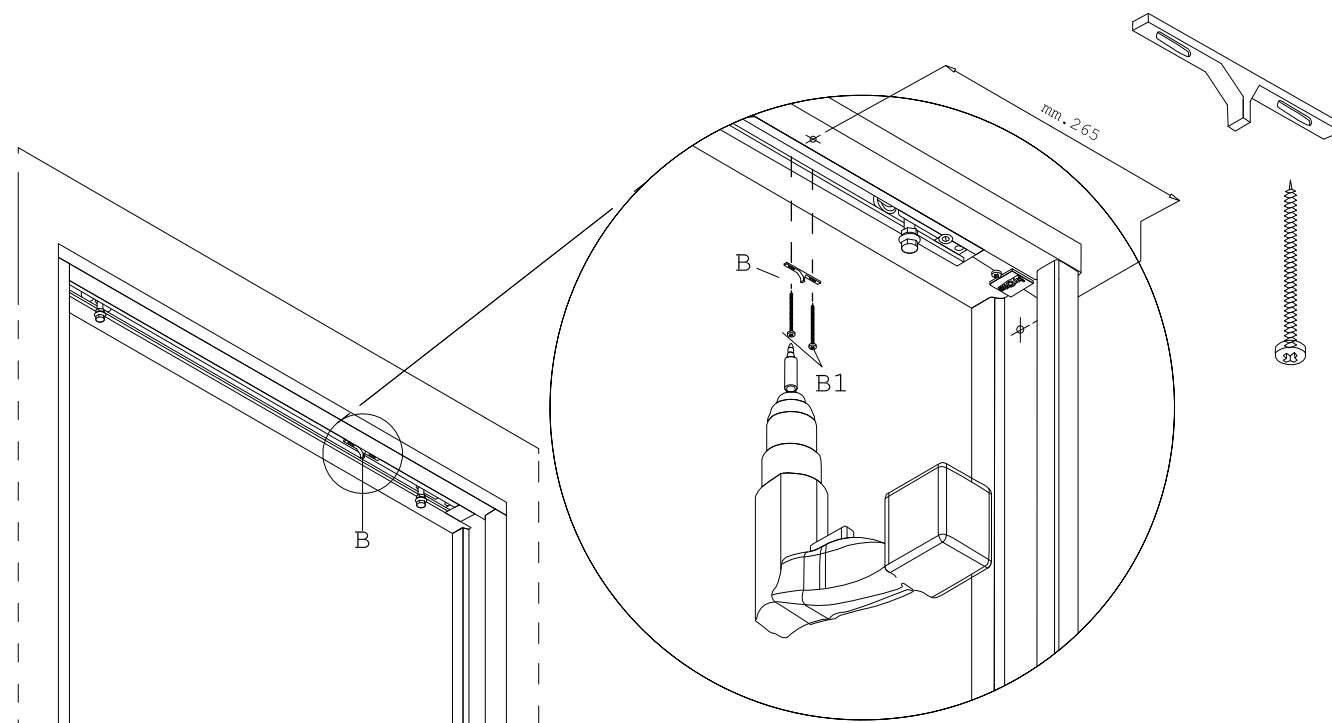

 *Fissare la staffa di chiusura "B" sul traverso. Utilizzare le viti in dotazione. Per il suo posizionamento fare riferimento alle quote indicate.

 * Fix closing bracket "B". Use screws contained in the kit. For the positioning kindly refer to the sizes indicated.

Contenuto del kit / Kit Contents:

N°1
Molla rallentatore /
Slow Spring

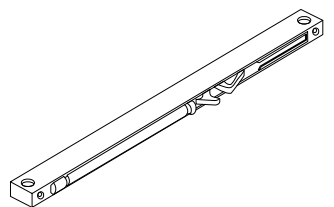

N°1
Staffetta d'aggancio /
Attachment Bracket

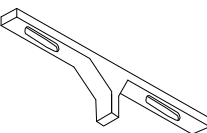

N°4
Viti di fissaggio /
Fixing Screws

